

2M x 8 - Bit Dynamic RAM 2k Refresh (Hyper Page Mode- EDO)

HYB5117805BSJ -50/-60/-70

Advanced Information

- 2 097 152 words by 8-bit organization
- 0 to 70 °C operating temperature
- Performance:

| | | -50 | -60 | -70 | |
|------------------|-------------------------------------|-----|-----|-----|----|
| t _{RAC} | $\overline{\text{RAS}}$ access time | 50 | 60 | 70 | ns |
| t _{CAC} | $\overline{\text{CAS}}$ access time | 13 | 15 | 20 | ns |
| t _{AA} | Access time from address | 25 | 30 | 35 | ns |
| t _{RC} | Read/Write cycle time | 84 | 104 | 124 | ns |
| t _{HPC} | Hyper page mode (EDO) cycle time | 20 | 25 | 30 | ns |

- Single + 5 V (± 10 %) supply
- Low power dissipation
max. 660 mW active (-50 version)
max. 605 mW active (-60 version)
max. 550 mW active (-70 version)
11 mW standby (TTL)
5.5. mW standby (MOS)
- Read, write, read-modify-write, $\overline{\text{CAS}}$ -before- $\overline{\text{RAS}}$ refresh, $\overline{\text{RAS}}$ -only refresh, hidden refresh, self refresh and test mode
- Hyper page mode (EDO) capability
- All inputs, outputs and clocks fully TTL-compatible
- 2048 refresh cycles / 32 ms (2k-Refresh)
- Plastic Package: P-SOJ-28-3 400 mil

The HYB 5117805BSJ is a 16 MBit dynamic RAM organized as 2 097 152 words by 8-bits. The HYB 5117805BSJ utilizes a submicron CMOS silicon gate process technology, as well as advanced circuit techniques to provide wide operating margins, both internally and for the system user. Multiplexed address inputs permit the HYB 5117805BSJ to be packaged in a standard SOJ 28 plastic package with 400 mil width. These packages provide high system bit densities and are compatible with commonly used automatic testing and insertion equipment. System-oriented features include single + 5 V ($\pm 10\%$) power supply, direct interfacing with high-performance logic device families such as Schottky TTL.

Ordering Information

| Type | Ordering Code | Package | Descriptions |
|------------------|---------------|--------------------|--------------------------|
| HYB 5117805BJ-50 | Q67100-Q1104 | P-SOJ-28-3 400 mil | DRAM (access time 50 ns) |
| HYB 5117805BJ-60 | Q67100-Q1105 | P-SOJ-28-3 400 mil | DRAM (access time 60 ns) |
| HYB 5117805BJ-70 | Q67100-Q1106 | P-SOJ-28-3 400 mil | DRAM (access time 70 ns) |

Pin Names

| | |
|-------------------------|-----------------------|
| A0-A10 | Row Address Inputs |
| A0-A9 | Column Address Inputs |
| $\overline{\text{RAS}}$ | Row Address Strobe |
| $\overline{\text{OE}}$ | Output Enable |
| I/O1-I/O8 | Data Input/Output |
| $\overline{\text{CAS}}$ | Column Address Strobe |
| $\overline{\text{WE}}$ | Read/Write Input |
| V_{CC} | Power Supply (+ 5 V) |
| V_{SS} | Ground (0 V) |
| N.C. | not connected |

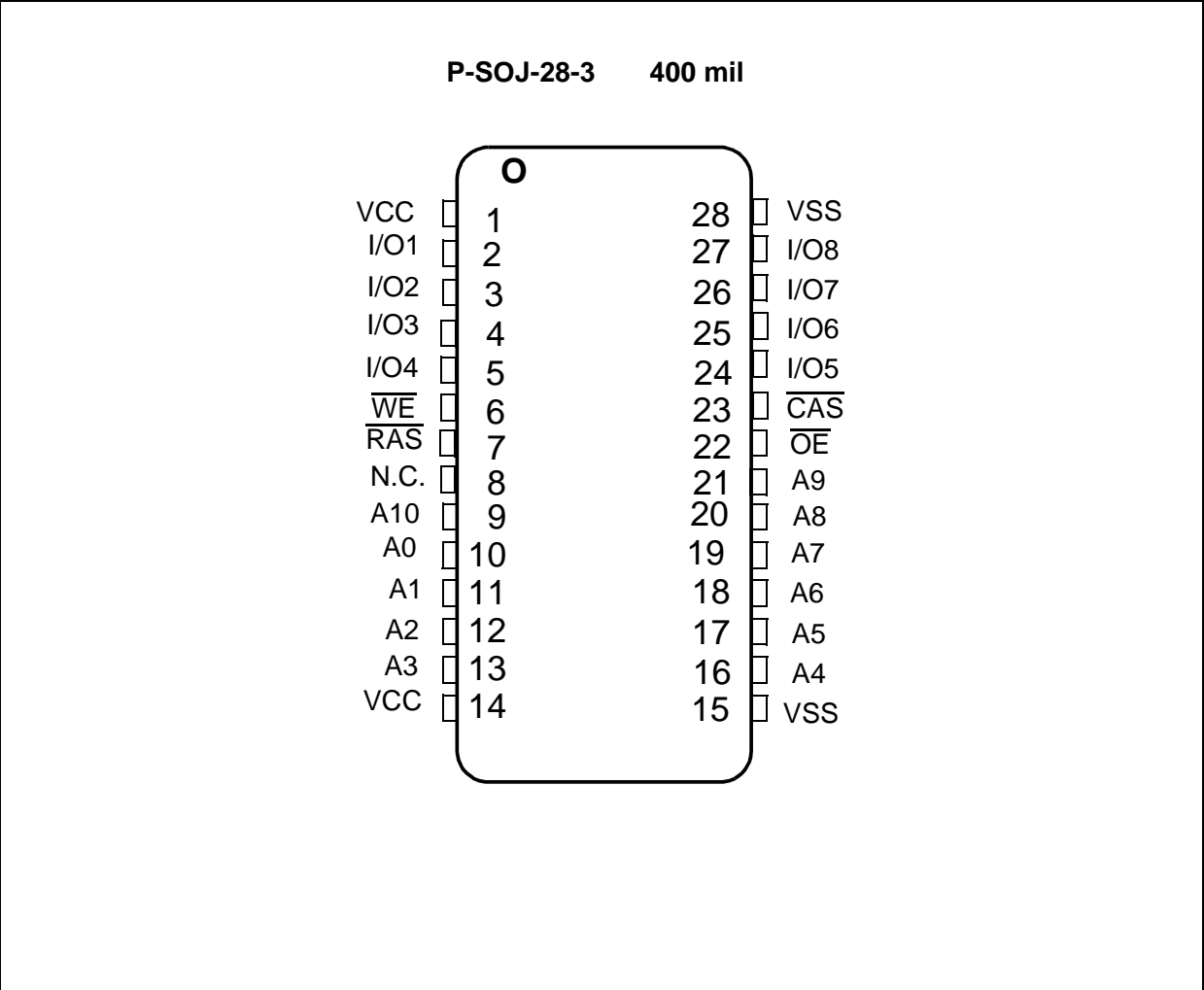

Pin Configuration

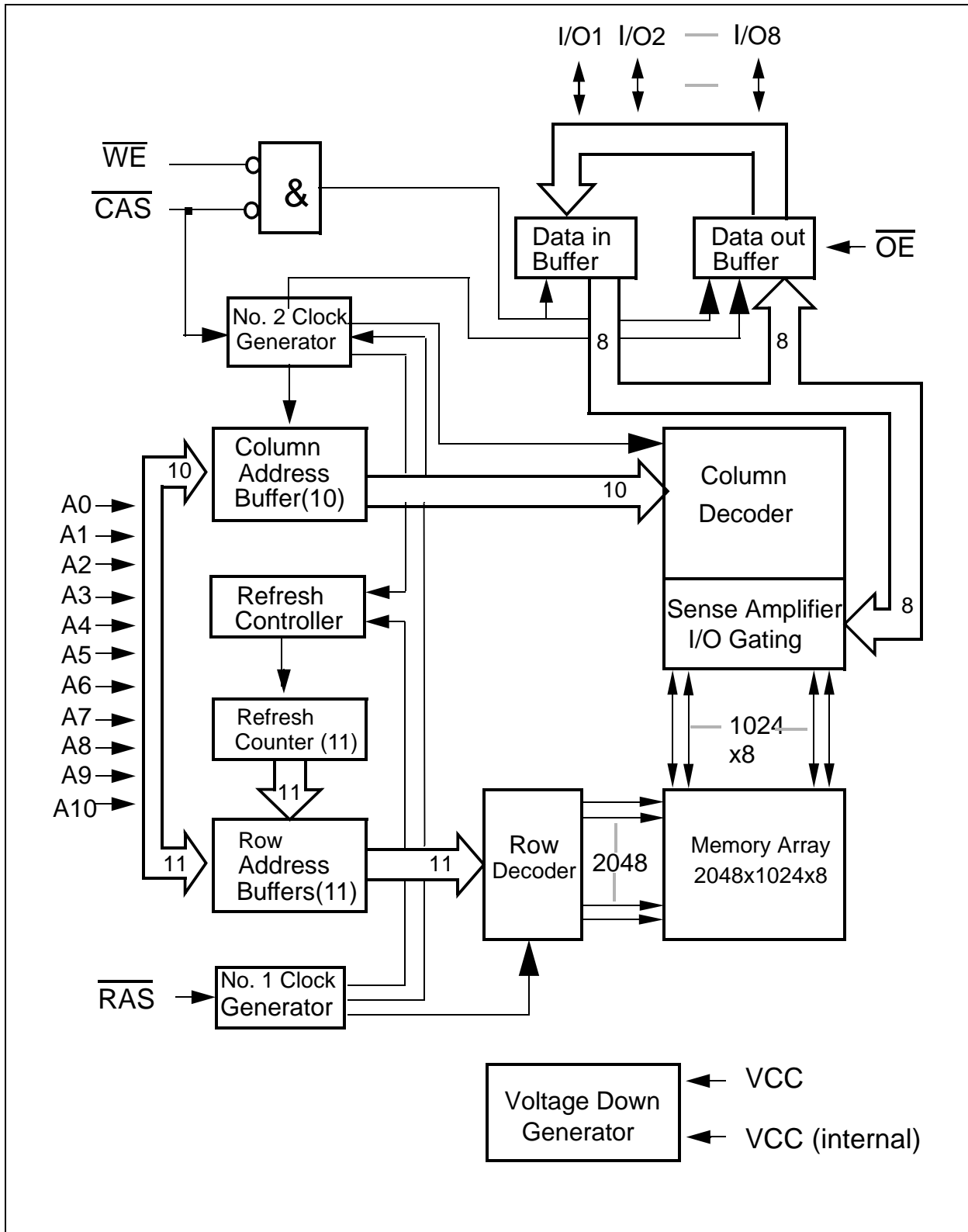

Block Diagram

Absolute Maximum Ratings

| | |
|--|--|
| Operating temperature range | 0 to 70 °C |
| Storage temperature range..... | – 55 to 150 °C |
| Input/output voltage | -0.5 to min (V _{CC} +0.5,7.0) V |
| Power supply voltage..... | -1.0V to 7.0 V |
| Power dissipation..... | 1.0 W |
| Data out current (short circuit) | 50 mA |

Note:

Stresses above those listed under “Absolute Maximum Ratings” may cause permanent damage of the device. Exposure to absolute maximum rating conditions for extended periods may affect device reliability.

DC Characteristics

$T_A = 0$ to 70 °C, $V_{SS} = 0$ V, $V_{CC} = 5$ V \pm 10 %; $t_T = 2$ ns

| Parameter | Symbol | Limit Values | | Unit | Test Condition |
|--|------------|--------------|-------------------|----------------|----------------------------------|
| | | min. | max. | | |
| Input high voltage | V_{IH} | 2.4 | $V_{CC}+0.5$ | V | 1) |
| Input low voltage | V_{IL} | – 0.5 | 0.8 | V | 1) |
| Output high voltage ($I_{OUT} = -5$ mA) | V_{OH} | 2.4 | – | V | 1) |
| Output low voltage ($I_{OUT} = 4.2$ mA) | V_{OL} | – | 0.4 | V | 1) |
| Input leakage current (0 V $\leq V_{IH} \leq V_{CC} + 0.3$ V, all other pins = 0 V) | $I_{I(L)}$ | – 10 | 10 | μ A | 1) |
| Output leakage current (DO is disabled, 0 V $\leq V_{OUT} \leq V_{CC} + 0.3$ V) | $I_{O(L)}$ | – 10 | 10 | μ A | 1) |
| Average V_{CC} supply current: <div style="margin-left: 20px;">-50 ns version</div> <div style="margin-left: 20px;">-60 ns version</div> <div style="margin-left: 20px;">-70 ns version</div> (\overline{RAS} , \overline{CAS} , address cycling: $t_{RC} = t_{RC}$ min.) | I_{CC1} | – | 120 110 100 | mA mA mA | 2) 3) 4) 2) 3) 4) 2) 3) 4) |
| Standby V_{CC} supply current ($\overline{RAS} = \overline{CAS} = V_{IH}$) | I_{CC2} | – | 2 | mA | – |
| Average V_{CC} supply current, during \overline{RAS} -only refresh cycles: <div style="margin-left: 20px;">-50 ns version</div> <div style="margin-left: 20px;">-60 ns version</div> <div style="margin-left: 20px;">-70 ns version</div> (\overline{RAS} cycling, $\overline{CAS} = V_{IH}$, $t_{RC} = t_{RC}$ min.) | I_{CC3} | – | 120 110 100 | mA mA mA | 2) 4) 2) 4) 2) 4) |

DC Characteristics

$T_A = 0$ to 70 °C, $V_{SS} = 0$ V, $V_{CC} = 5$ V \pm 10 %; $t_T = 2$ ns

| Parameter | Symbol | Limit Values | | Unit | Test Condition |
|--|-----------|--------------|-------------------|----------------|----------------------------------|
| | | min. | max. | | |
| Average V_{CC} supply current, during hyper page mode: -50 ns version -60 ns version -70 ns version ($\overline{RAS} = V_{IL}$, \overline{CAS} , address cycling: $t_{PC} = t_{PC}$ min.) | I_{CC4} | – | 70 55 45 | mA mA mA | 2) 3) 4) 2) 3) 4) 2) 3) 4) |
| Standby V_{CC} supply current ($\overline{RAS} = \overline{CAS} = V_{CC} - 0.2$ V) | I_{CC5} | – | 1 | mA | 1) |
| Average V_{CC} supply current, during \overline{CAS} -before-RAS refresh mode: -50 ns version -60 ns version -70 ns version (\overline{RAS} , \overline{CAS} cycling: $t_{RC} = t_{RC}$ min.) | I_{CC6} | – | 120 110 100 | mA mA mA | 2) 4) 2) 4) 2) 4) |
| Average Self Refresh Current (CBR cycle with $t_{RAS} > TRASS_{min.}$, \overline{CAS} held low, $\overline{WE} = V_{CC} - 0.2$ V, Address and Din = $V_{CC} - 0.2$ V or 0.2V) | I_{CC7} | – | 1 | mA | |

Capacitance

$T_A = 0$ to 70 °C, $V_{CC} = 5$ V \pm 10 %, $f = 1$ MHz

| Parameter | Symbol | Limit Values | | Unit |
|---|----------|--------------|------|------|
| | | min. | max. | |
| Input capacitance (A0 to A10) | C_{I1} | – | 5 | pF |
| Input capacitance (\overline{RAS} , \overline{CAS} , \overline{WE} , \overline{OE}) | C_{I2} | – | 7 | pF |
| I/O capacitance (I/O1-I/O8) | C_{I0} | – | 7 | pF |

AC Characteristics ⁵⁾⁶⁾

16E

$T_A = 0$ to 70 °C, $V_{CC} = 5$ V \pm 10 %, $t_T = 2$ ns

| Parameter | Symbol | Limit Values | | | | | | Unit | Note |
|-----------|--------|--------------|------|------|------|------|------|------|------|
| | | -50 | | -60 | | -70 | | | |
| | | min. | max. | min. | max. | min. | max. | | |

common parameters

| | | | | | | | | | |
|---|-----------|----|-----|-----|-----|-----|-----|----|---|
| Random read or write cycle time | t_{RC} | 84 | – | 104 | – | 124 | – | ns | |
| \overline{RAS} precharge time | t_{RP} | 30 | – | 40 | – | 50 | – | ns | |
| \overline{RAS} pulse width | t_{RAS} | 50 | 10k | 60 | 10k | 70 | 10k | ns | |
| \overline{CAS} pulse width | t_{CAS} | 8 | 10k | 10 | 10k | 12 | 10k | ns | |
| Row address setup time | t_{ASR} | 0 | – | 0 | – | 0 | – | ns | |
| Row address hold time | t_{RAH} | 8 | – | 10 | – | 10 | – | ns | |
| Column address setup time | t_{ASC} | 0 | – | 0 | – | 0 | – | ns | |
| Column address hold time | t_{CAH} | 8 | – | 10 | – | 12 | – | ns | |
| \overline{RAS} to \overline{CAS} delay time | t_{RCD} | 12 | 37 | 14 | 45 | 14 | 53 | ns | |
| \overline{RAS} to column address delay | t_{RAD} | 10 | 25 | 12 | 30 | 12 | 35 | ns | |
| \overline{RAS} hold time | t_{RSH} | 13 | | 15 | – | 17 | – | ns | |
| \overline{CAS} hold time | t_{CSH} | 40 | | 50 | – | 60 | – | ns | |
| \overline{CAS} to \overline{RAS} precharge time | t_{CRP} | 5 | – | 5 | – | 5 | – | ns | |
| Transition time (rise and fall) | t_T | 1 | 50 | 1 | 50 | 1 | 50 | ns | 7 |
| Refresh period | t_{REF} | – | 32 | – | 32 | – | 32 | ms | |

Read Cycle

| | | | | | | | | | |
|---|-----------|----|----|----|----|----|----|----|------|
| Access time from \overline{RAS} | t_{RAC} | – | 50 | – | 60 | – | 70 | ns | 8, 9 |
| Access time from \overline{CAS} | t_{CAC} | – | 13 | – | 15 | – | 17 | ns | 8, 9 |
| Access time from column address | t_{AA} | – | 25 | – | 30 | – | 35 | ns | 8,10 |
| \overline{OE} access time | t_{OEA} | – | 13 | – | 15 | – | 17 | ns | |
| Column address to \overline{RAS} lead time | t_{RAL} | 25 | – | 30 | – | 35 | – | ns | |
| Read command setup time | t_{RCS} | 0 | – | 0 | – | 0 | – | ns | |
| Read command hold time | t_{RCH} | 0 | – | 0 | – | 0 | – | ns | 11 |
| Read command hold time referenced to \overline{RAS} | t_{RRH} | 0 | – | 0 | – | 0 | – | ns | 11 |
| \overline{CAS} to output in low-Z | t_{CLZ} | 0 | – | 0 | – | 0 | – | ns | 8 |
| Output buffer turn-off delay | t_{OFF} | 0 | 13 | 0 | 15 | 0 | 17 | ns | 12 |
| Output turn-off delay from \overline{OE} | t_{OEZ} | 0 | 13 | 0 | 15 | 0 | 17 | ns | 12 |

AC Characteristics *(cont'd)* 5)6)

16E

$T_A = 0$ to 70 °C, $V_{CC} = 5$ V \pm 10 %, $t_T = 2$ ns

| Parameter | Symbol | Limit Values | | | | | | Unit | Note |
|--|-----------|--------------|------|------|------|------|------|------|------|
| | | -50 | | -60 | | -70 | | | |
| | | min. | max. | min. | max. | min. | max. | | |
| Data to $\overline{\text{CAS}}$ low delay | t_{DZC} | 0 | – | 0 | – | 0 | – | ns | 13 |
| Data to $\overline{\text{OE}}$ low delay | t_{DZO} | 0 | – | 0 | – | 0 | – | ns | 13 |
| $\overline{\text{CAS}}$ high to data delay | t_{CDD} | 10 | – | 13 | – | 15 | – | ns | 14 |
| $\overline{\text{OE}}$ high to data delay | t_{ODD} | 10 | – | 13 | – | 15 | – | ns | 14 |

Write Cycle

| | | | | | | | | | |
|--|-----------|----|---|----|---|----|---|----|----|
| Write command hold time | t_{WCH} | 8 | – | 10 | – | 10 | – | ns | |
| Write command pulse width | t_{WCP} | 8 | – | 10 | – | 10 | – | ns | |
| Write command setup time | t_{WCS} | 0 | – | 0 | – | 0 | – | ns | 15 |
| Write command to $\overline{\text{RAS}}$ lead time | t_{RWL} | 13 | – | 15 | – | 17 | – | ns | |
| Write command to $\overline{\text{CAS}}$ lead time | t_{CWL} | 13 | – | 15 | – | 17 | – | ns | |
| Data setup time | t_{DS} | 0 | – | 0 | – | 0 | – | ns | 16 |
| Data hold time | t_{DH} | 8 | – | 10 | – | 12 | – | ns | 16 |

Read-modify-Write Cycle

| | | | | | | | | | |
|--|-----------|-----|---|-----|---|-----|---|----|----|
| Read-write cycle time | t_{RWC} | 113 | – | 138 | – | 162 | – | ns | |
| $\overline{\text{RAS}}$ to $\overline{\text{WE}}$ delay time | t_{RWD} | 64 | – | 77 | – | 89 | – | ns | 15 |
| $\overline{\text{CAS}}$ to $\overline{\text{WE}}$ delay time | t_{CWD} | 27 | – | 32 | – | 36 | – | ns | 15 |
| Column address to $\overline{\text{WE}}$ delay time | t_{AWD} | 39 | – | 47 | – | 54 | – | ns | 15 |
| $\overline{\text{OE}}$ command hold time | t_{OEH} | 10 | – | 13 | – | 15 | – | ns | |

Hyper Page Mode (EDO) Cycle

| | | | | | | | | | |
|--|------------|----|------|----|------|----|------|----|---|
| Hyper page mode (EDO) cycle time | t_{HPC} | 20 | – | 25 | – | 30 | – | ns | |
| $\overline{\text{CAS}}$ precharge time | t_{CP} | 8 | – | 10 | – | 10 | – | ns | |
| Access time from $\overline{\text{CAS}}$ precharge | t_{CPA} | – | 27 | – | 32 | – | 37 | ns | 7 |
| Output data hold time | t_{COH} | 5 | – | 5 | – | 5 | – | ns | |
| $\overline{\text{RAS}}$ pulse width in EDO mode | t_{RAS} | 50 | 200k | 60 | 200k | 70 | 200k | ns | |
| $\overline{\text{CAS}}$ precharge to $\overline{\text{RAS}}$ Delay | t_{RHPC} | 27 | – | 32 | – | 37 | – | ns | |

AC Characteristics (cont'd) 5)6)

16E

 $T_A = 0 \text{ to } 70 \text{ }^\circ\text{C}, V_{CC} = 5 \text{ V} \pm 10 \%, t_T = 2 \text{ ns}$

| Parameter | Symbol | Limit Values | | | | | | Unit | Note |
|-----------|--------|--------------|------|------|------|------|------|------|------|
| | | -50 | | -60 | | -70 | | | |
| | | min. | max. | min. | max. | min. | max. | | |

Hyper Page Mode (EDO) Read-modify-Write Cycle

| | | | | | | | | | |
|---|------------|----|---|----|---|----|---|----|--|
| Hyper page mode (EDO) read-write cycle time | t_{PRWC} | 58 | – | 68 | – | 77 | – | ns | |
| $\overline{\text{CAS}}$ precharge to $\overline{\text{WE}}$ | t_{CPWD} | 41 | – | 49 | – | 56 | – | ns | |

$\overline{\text{CAS}}$ -before- $\overline{\text{RAS}}$ Refresh Cycle

| | | | | | | | | | |
|---|-----------|----|---|----|---|----|---|----|--|
| $\overline{\text{CAS}}$ setup time | t_{CSR} | 10 | – | 10 | – | 10 | – | ns | |
| $\overline{\text{CAS}}$ hold time | t_{CHR} | 10 | – | 10 | – | 10 | – | ns | |
| $\overline{\text{RAS}}$ to $\overline{\text{CAS}}$ precharge time | t_{RPC} | 5 | – | 5 | – | 5 | – | ns | |
| Write to $\overline{\text{RAS}}$ precharge time | t_{WRP} | 10 | – | 10 | – | 10 | – | ns | |
| Write hold time referenced to $\overline{\text{RAS}}$ | t_{WRH} | 10 | – | 10 | – | 10 | – | ns | |

$\overline{\text{CAS}}$ -before- $\overline{\text{RAS}}$ Counter Test Cycle

| | | | | | | | | | |
|---|-----------|----|---|----|---|----|---|----|--|
| $\overline{\text{CAS}}$ precharge time ($\overline{\text{CAS}}$ -before- $\overline{\text{RAS}}$ counter test cycle) | t_{CPT} | 35 | – | 40 | – | 40 | – | ns | |
|---|-----------|----|---|----|---|----|---|----|--|

Self Refresh Cycle

| | | | | | | | | | |
|--|------------|------|---|------|---|------|---|----|----|
| $\overline{\text{RAS}}$ pulse width | t_{RASS} | 100k | – | 100k | – | 100k | – | ns | 17 |
| $\overline{\text{RAS}}$ precharge time | t_{RPS} | 95 | – | 110 | – | 130 | – | ns | 17 |
| $\overline{\text{CAS}}$ hold time | t_{CHS} | -50 | – | -50 | – | -50 | – | ns | 17 |

Test Mode

| | | | | | | | | | |
|-----------------------------------|------------|----|---|----|---|----|---|----|--|
| Write command setup time | t_{WTS} | 10 | – | 10 | – | 10 | – | ns | |
| Write command hold time | t_{WTH} | 10 | – | 10 | – | 10 | – | ns | |
| $\overline{\text{CAS}}$ hold time | t_{CHRT} | 30 | – | 30 | – | 30 | – | ns | |

Notes:

- 1) All voltages are referenced to V_{SS} .
- 2) I_{CC1} , I_{CC3} , I_{CC4} and I_{CC6} depend on cycle rate.
- 3) I_{CC1} and I_{CC4} depend on output loading. Specified values are obtained with the output open.
- 4) Address can be changed once or less while $RAS = \overline{Vil}$. In case of ICC4 it can be changed once or less during a hyper page mode (EDO) cycle
- 5) An initial pause of 200 μs is required after power-up followed by 8 \overline{RAS} cycles of which at least one cycle has to be a refresh cycle, before proper device operation is achieved. In case of using the internal refresh counter, a minimum of 8 CAS-before-RAS initialization cycles instead of 8 \overline{RAS} cycles are required.
- 6) AC measurements assume $t_T = 2$ ns.
- 7) $V_{IH (min.)}$ and $V_{IL (max.)}$ are reference levels for measuring timing of input signals. Transition times are also measured between V_{IH} and V_{IL} .
- 8) Measured with the specified current load and 100 pF at $V_{ol} = 0.8$ V and $V_{oh} = 2.0$ V. Access time is determined by the latter of t_{RAC} , t_{CAC} , t_{AA} , t_{CPA} , t_{OEA} . t_{CAC} is measured from tristate.
- 9) Operation within the $t_{RCD (max.)}$ limit ensures that $t_{RAC (max.)}$ can be met. $t_{RCD (max.)}$ is specified as a reference point only. If t_{RCD} is greater than the specified $t_{RCD (max.)}$ limit, then access time is controlled by t_{CAC} .
- 10) Operation within the $t_{RAD (max.)}$ limit ensures that $t_{RAC (max.)}$ can be met. $t_{RAD (max.)}$ is specified as a reference point only. If t_{RAD} is greater than the specified $t_{RAD (max.)}$ limit, then access time is controlled by t_{AA} .
- 11) Either t_{RCH} or t_{RRH} must be satisfied for a read cycle.
- 12) $t_{OFF (max.)}$, $t_{OEZ (max.)}$ define the time at which the output achieves the open-circuit conditions and are not referenced to output voltage levels. t_{OFF} is referenced from the rising edge of \overline{RAS} or \overline{CAS} , whichever occurs last.
- 13) Either t_{DZC} or t_{DZO} must be satisfied.
- 14) Either t_{CDD} or t_{ODD} must be satisfied.
- 15) t_{WCS} , t_{RWD} , t_{CWD} and t_{AWD} are not restrictive operating parameters. They are included in the data sheet as electrical characteristics only. If $t_{WCS} > t_{WCS (min.)}$, the cycle is an early write cycle and data out pin will remain open-circuit (high impedance) through the entire cycle; if $t_{RWD} > t_{RWD (min.)}$, $t_{CWD} > t_{CWD (min.)}$ and $t_{AWD} > t_{AWD (min.)}$, the cycle is a read-write cycle and I/O will contain data read from the selected cells. If neither of the above sets of conditions is satisfied, the condition of I/O (at access time) is indeterminate.
- 16) These parameters are referenced to the \overline{CAS} leading edge in early write cycles and to the \overline{WE} leading edge in read-write cycles.
- 17) When using Self Refresh mode, the following refresh operations must be performed to ensure proper DRAM operation:

If row addresses are being refreshed on an evenly distributed manner over the refresh interval using CBR refresh cycles, then only one CBR cycle must be performed immediately after exit from Self Refresh.

If row addresses are being refreshed in any other manner (ROR - Distributed/Burst; or CBR-Burst) over the refresh interval, then a full set of row refreshes must be performed immediately before entry to and immediately after exit from Self Refresh

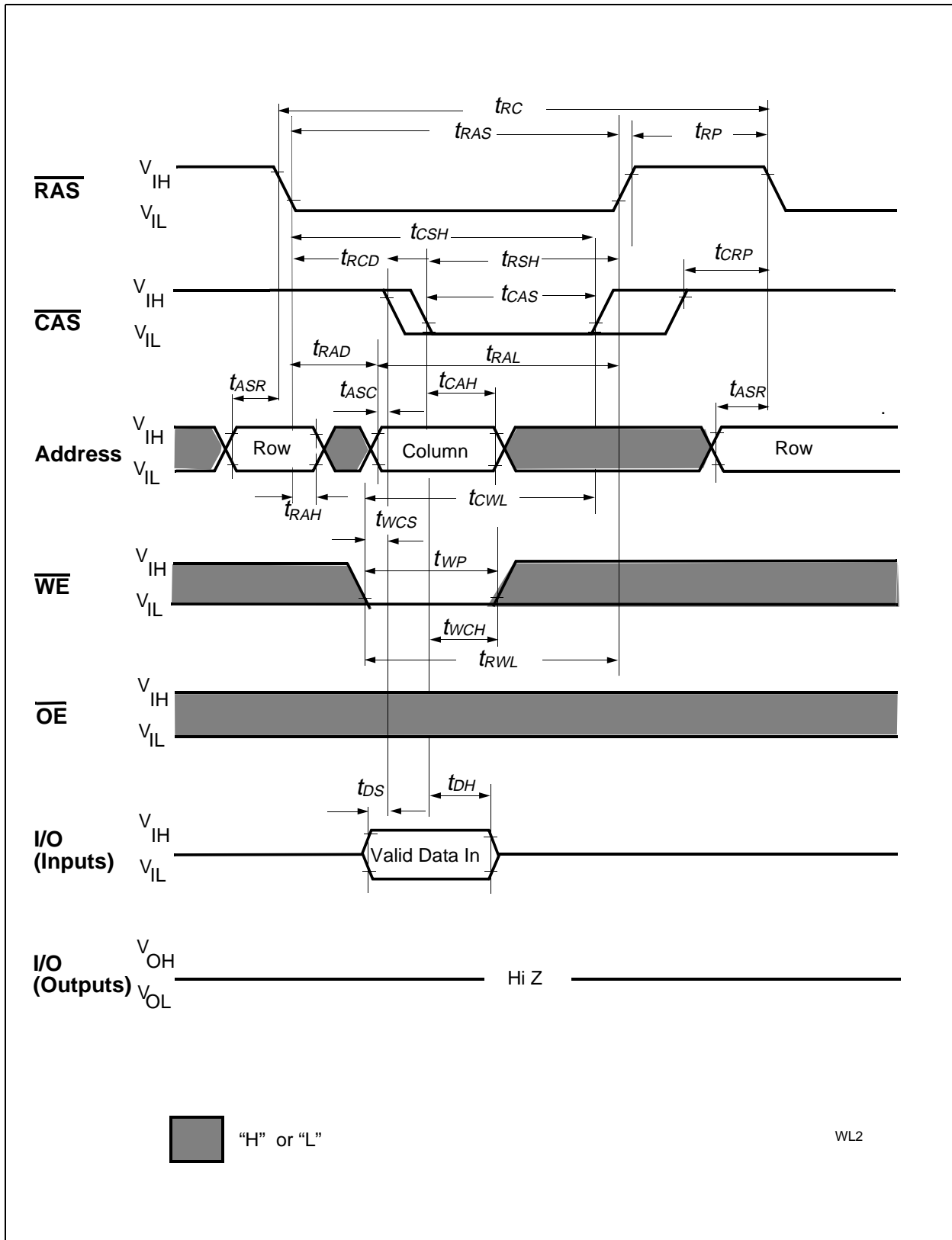

Write Cycle (Early Write)

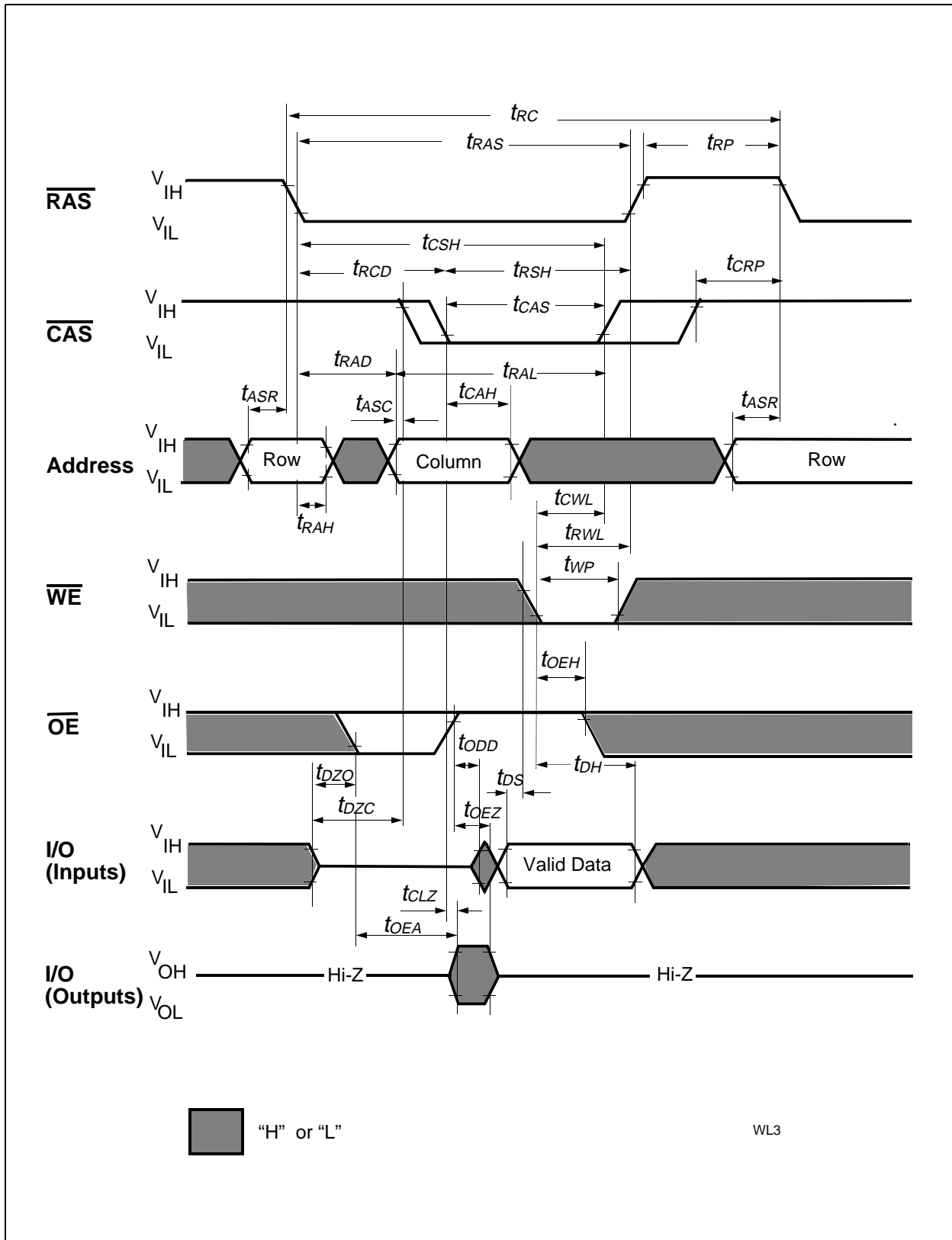

Write Cycle (\overline{OE} Controlled Write)

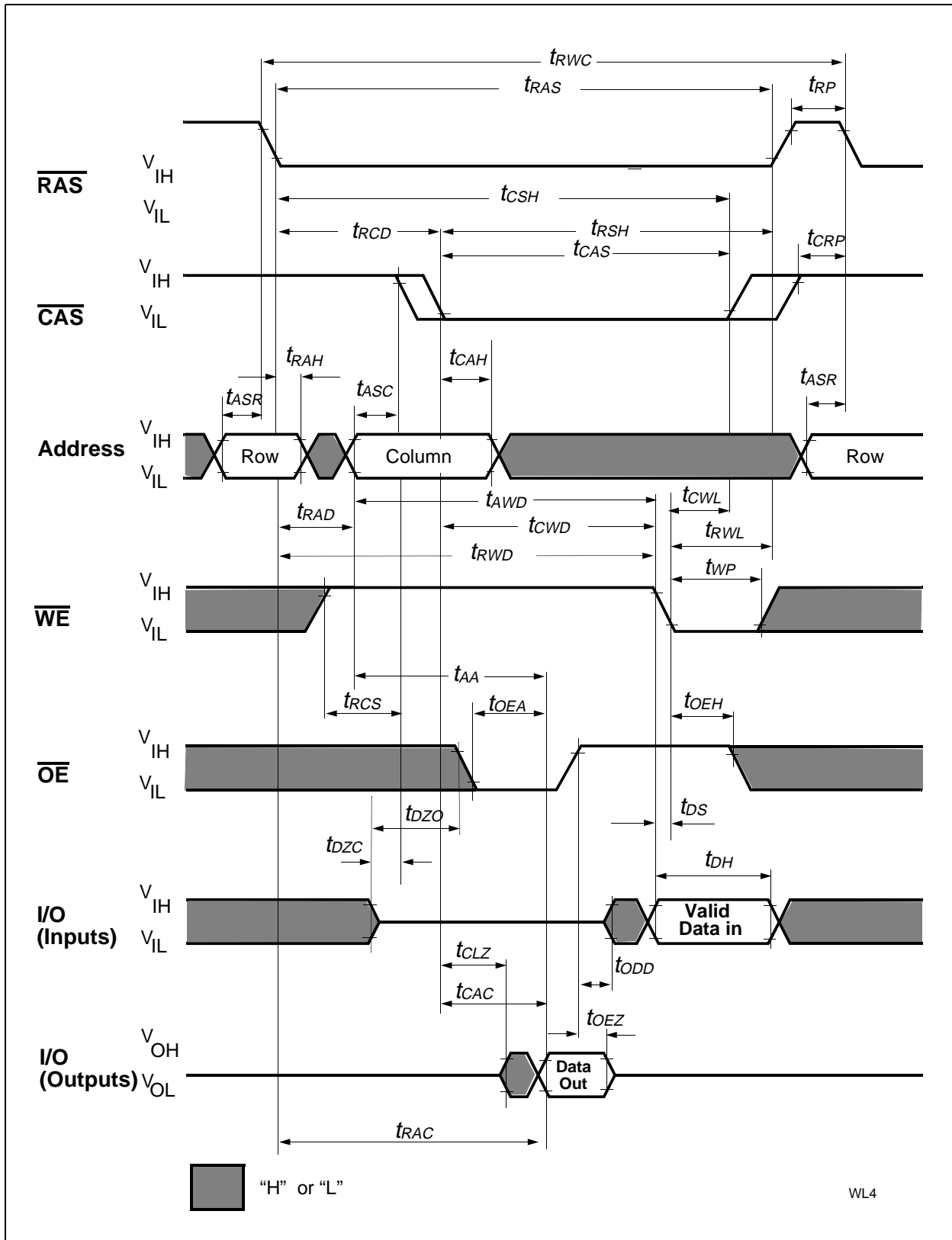

Read-Write (Read-Modify-Write) Cycle

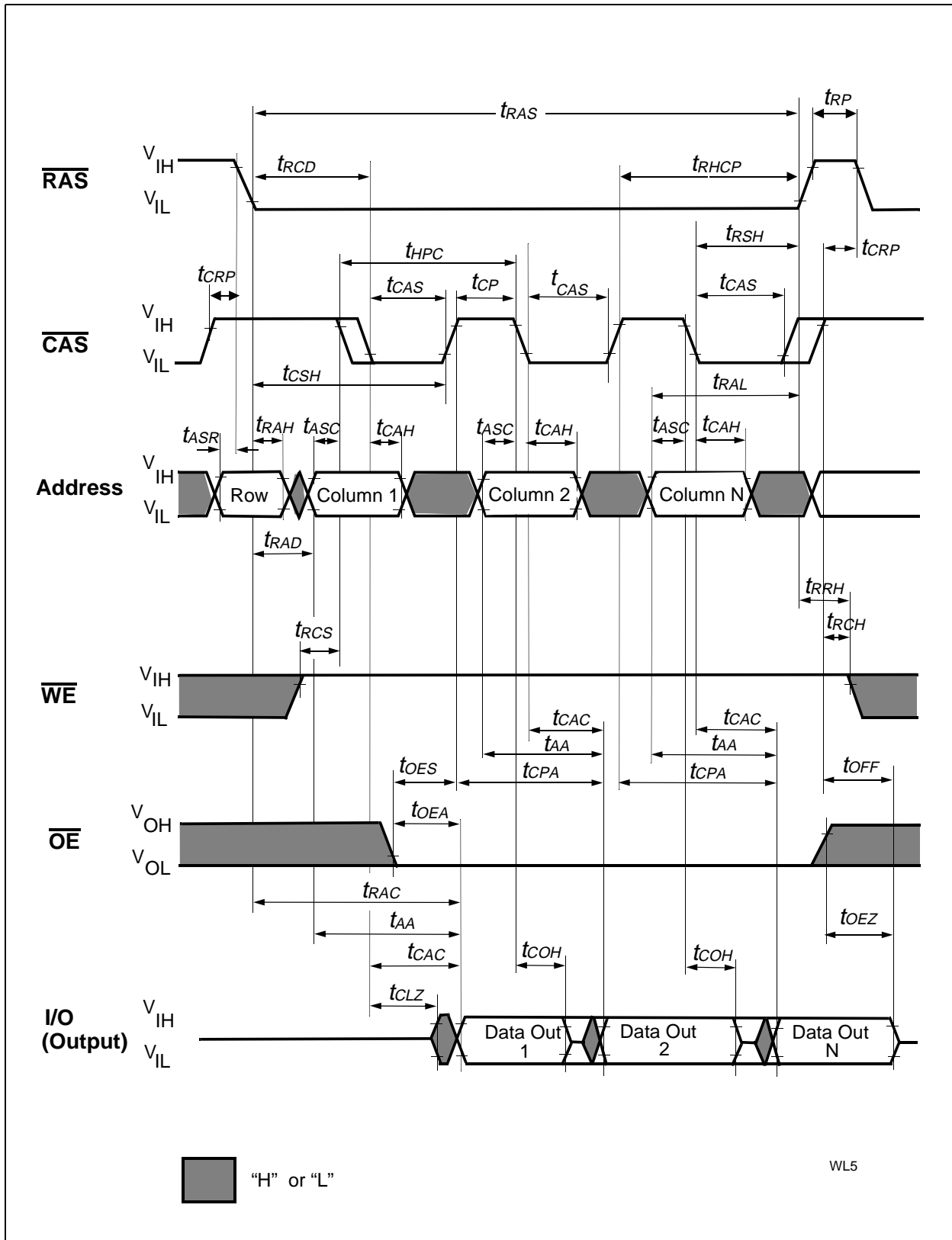

Hyper Page Mode (EDO) Read Cycle

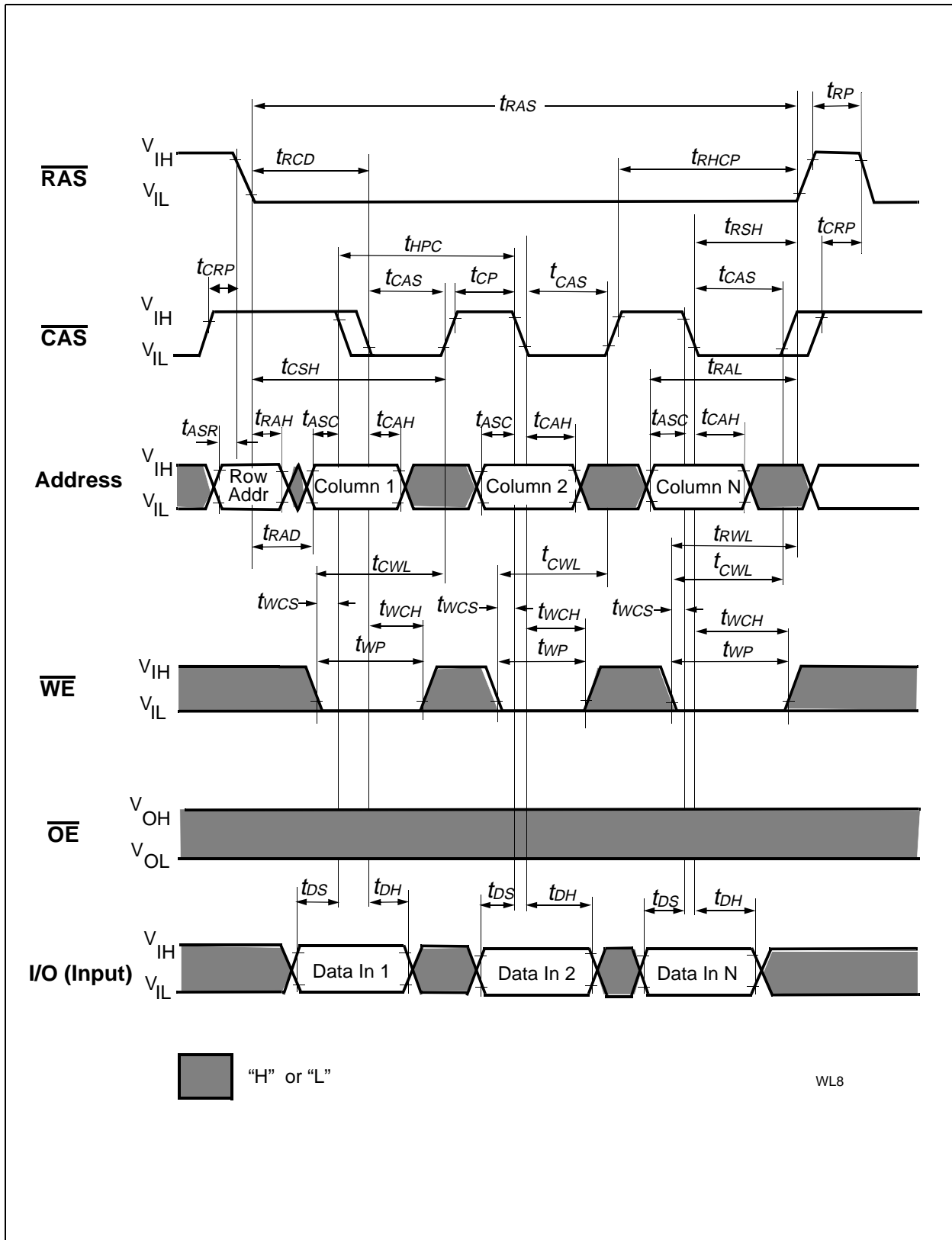

Hyper Page Mode (EDO) Early Write Cycle

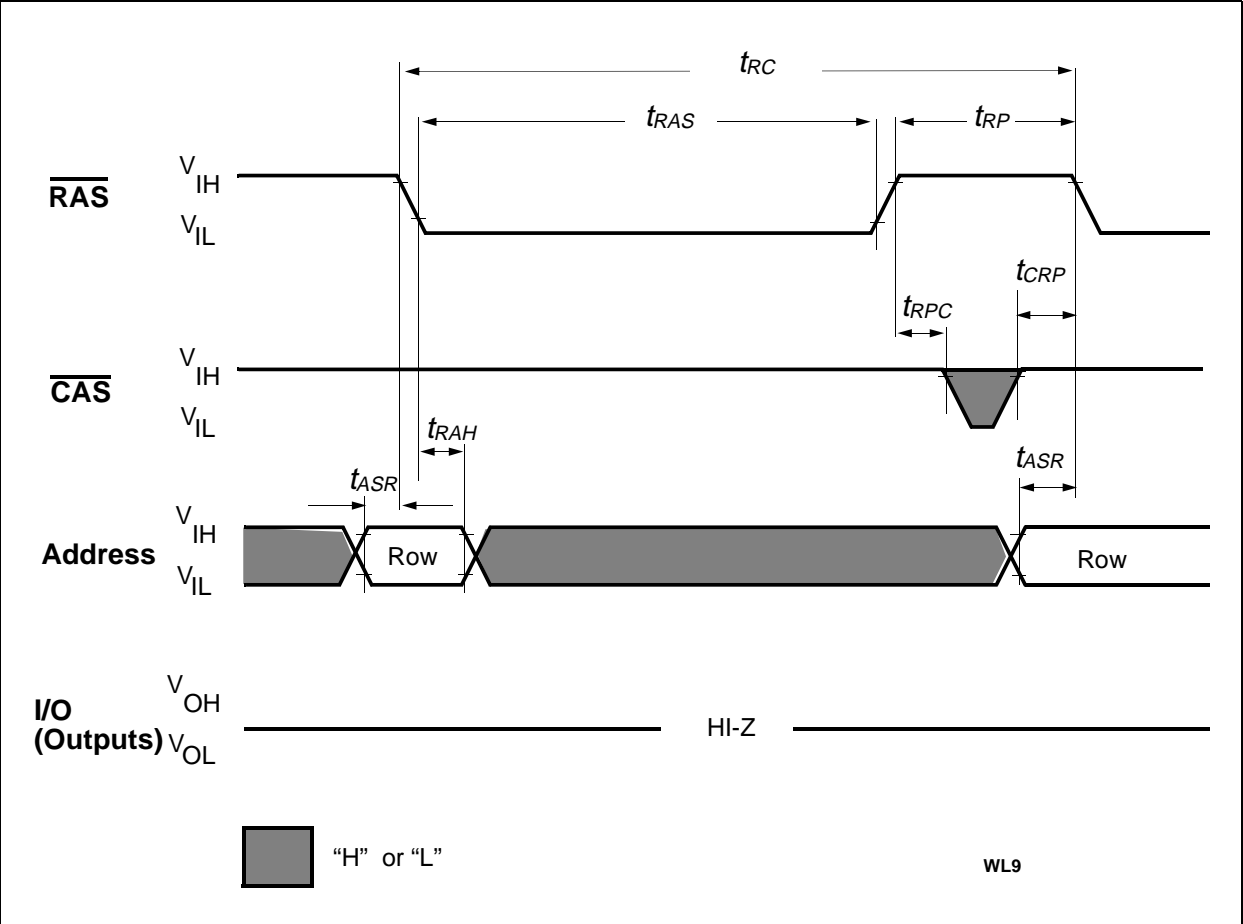

$\overline{\text{RAS}}$ -Only Refresh Cycle

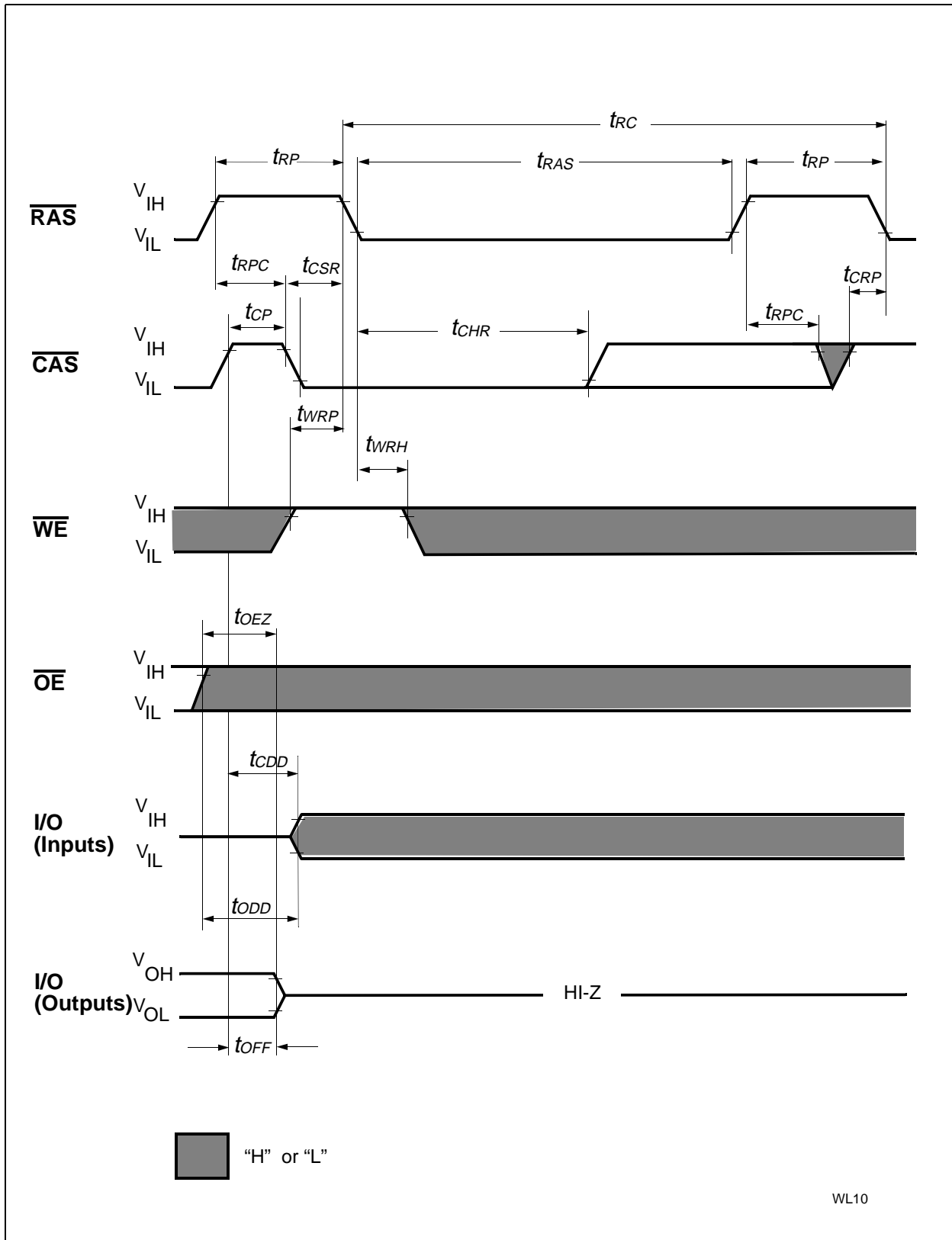

CAS-Before-RAS Refresh Cycle

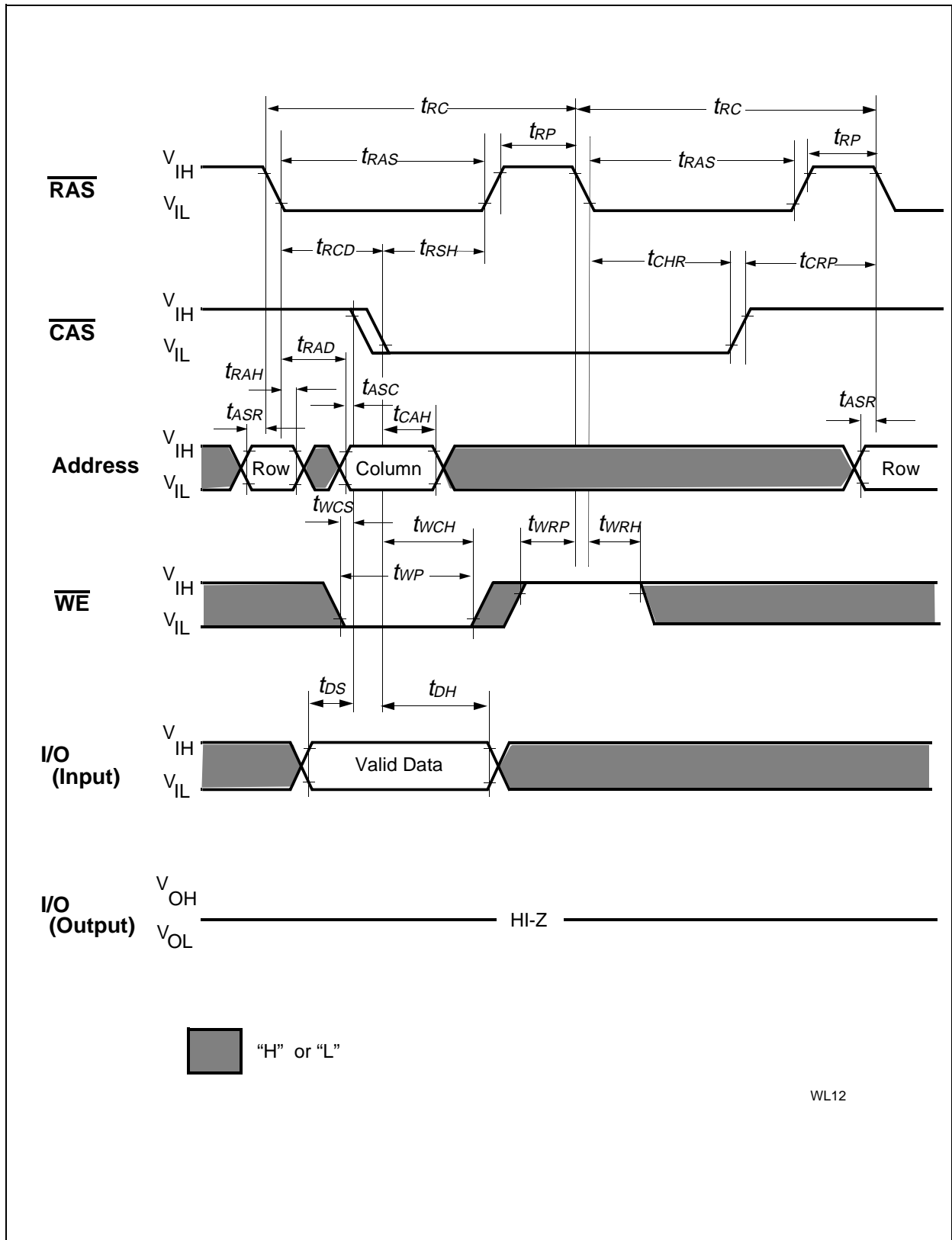

Hidden Refresh Early Write Cycle

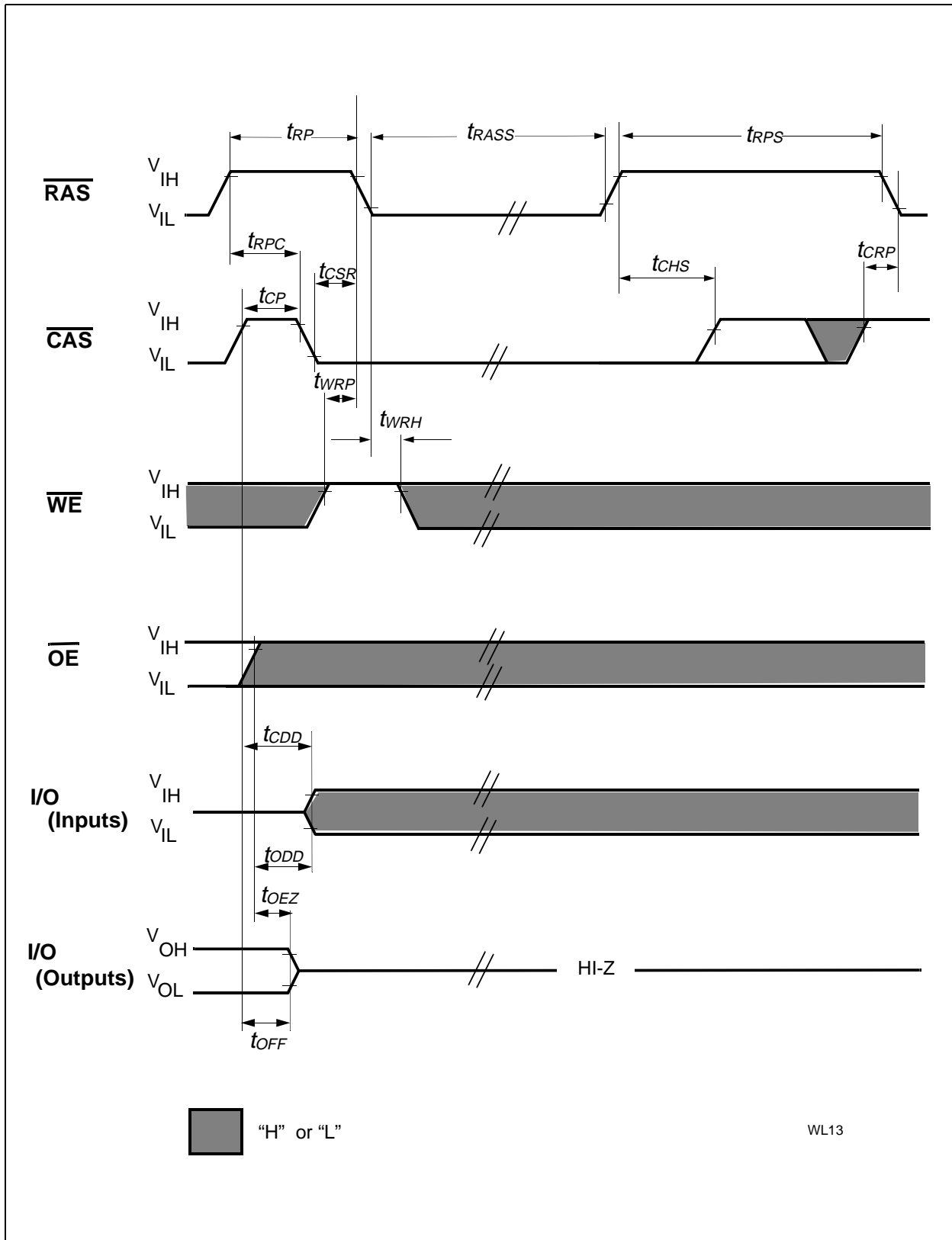

Self Refresh

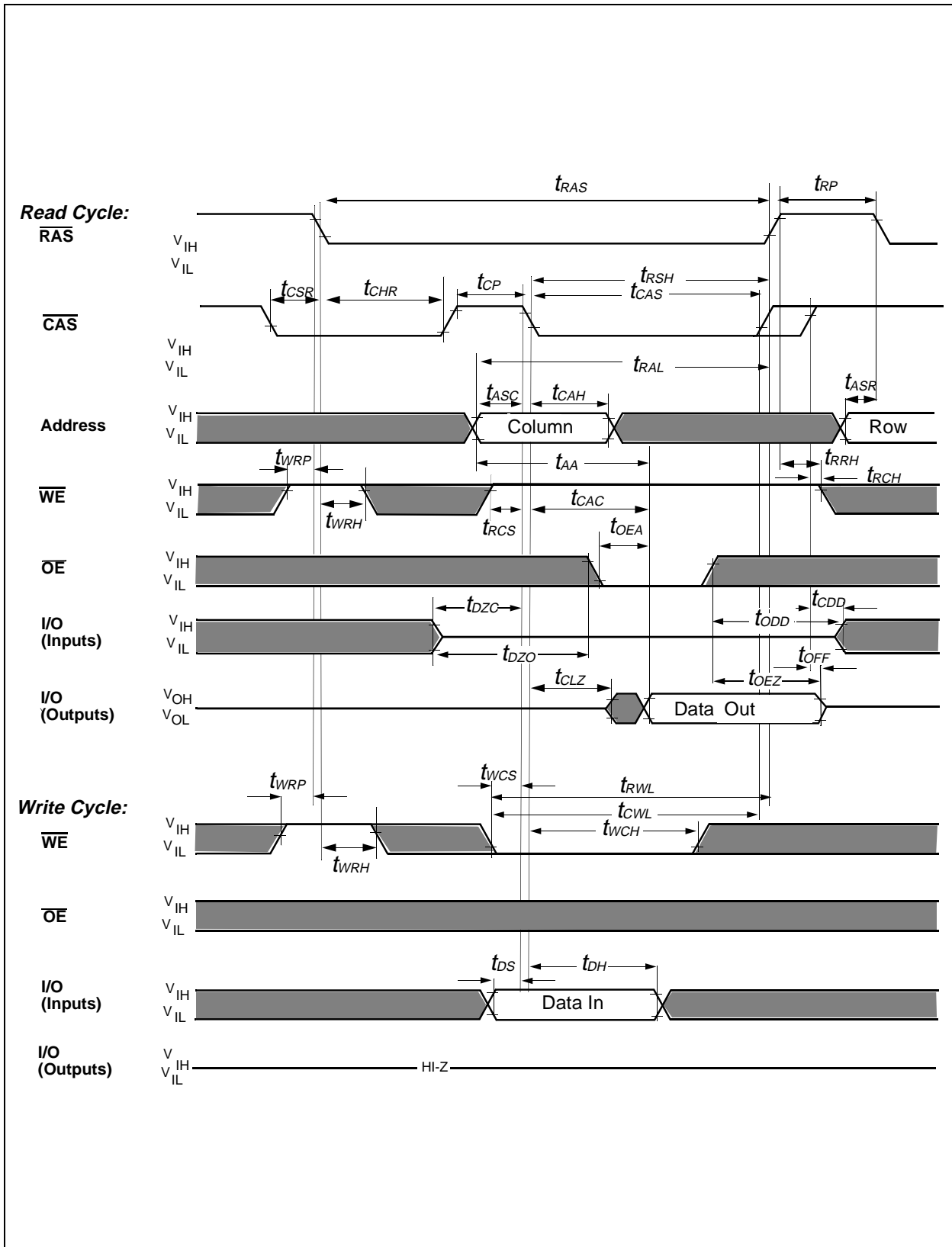

$\overline{\text{CAS}}$ -Before- $\overline{\text{RAS}}$ Refresh Counter Test Cycle

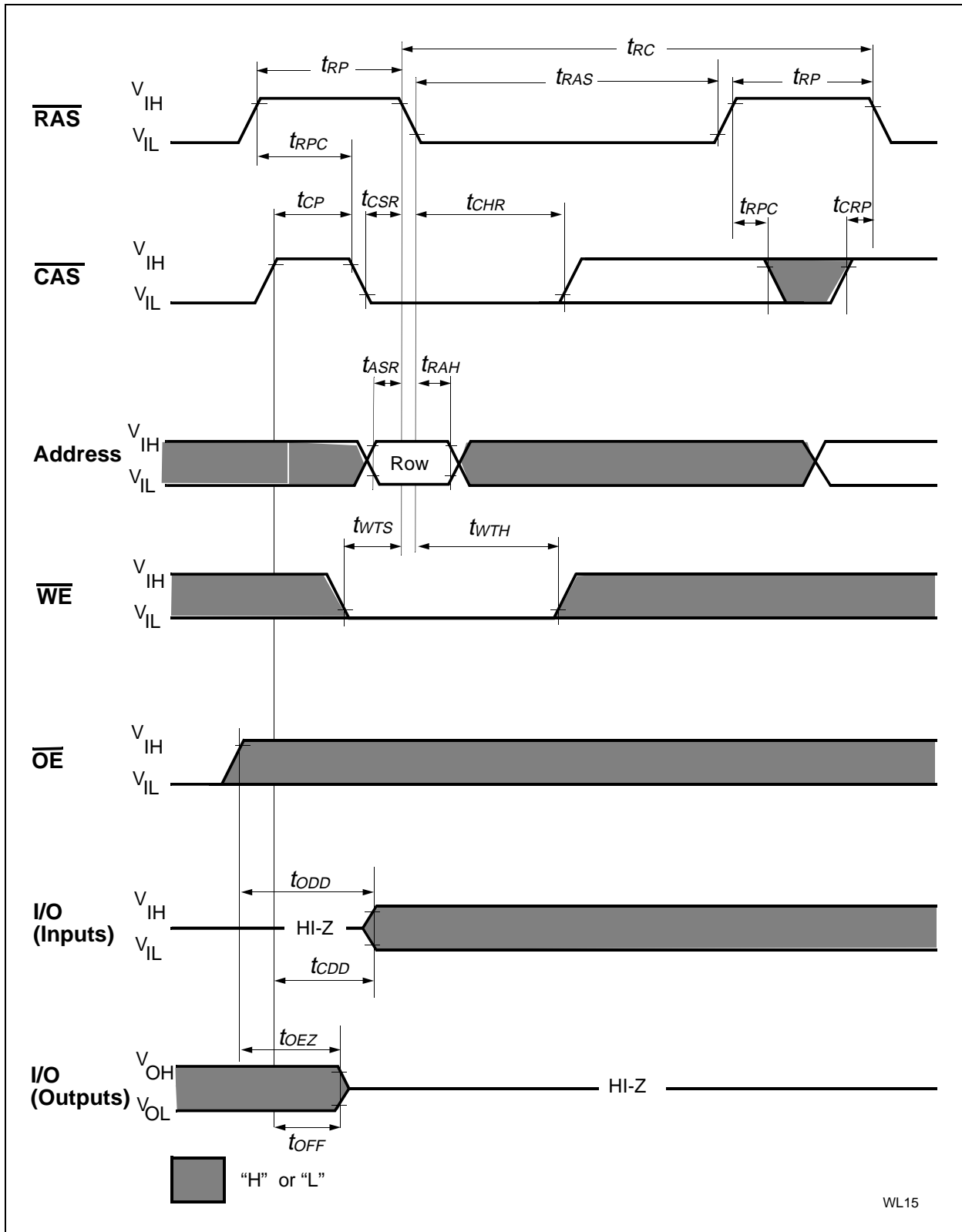

Test Mode Entry

Plastic Package P-SOJ-28-3 (400mil) (Small Outline J-lead, SMD)

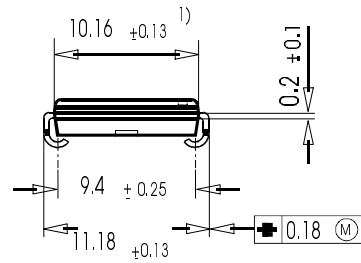
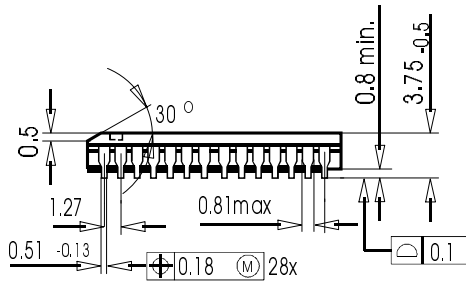

GPJ05699

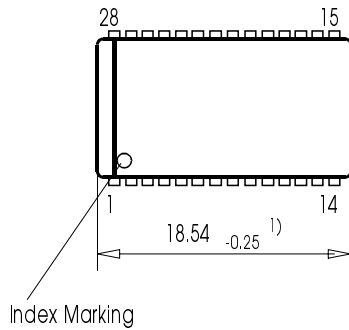

Index Marking

1) Does not include plastic or metal protrusion of 0.15 max. per side

Package Outline